

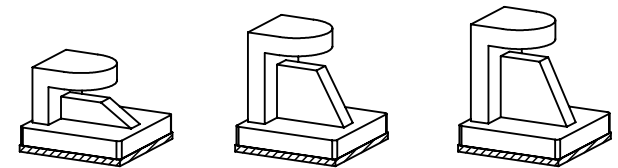

NOTES:

- MATERIAL FLAMABILITY RATING: UL94V-2
- ADHESIVE: 3M DOUBLE COATED URETHANE FOAM TAPE
- CUSTOM MATERIAL/TAPE/COLOR AVAILABLE

PART NO.	REF "B"		REF "C"		REF "D"	
	MM	INCH	MM	INCH	MM	INCH
PCBS-UB-6F	11.0	0.433	2.2	0.087	6.4	0.252
PCBS-UB-11F	15.8	0.622	2.5	0.098	10.8	0.425
PCBS-UB-12F	16.9	0.665	2.3	0.091	12.0	0.472

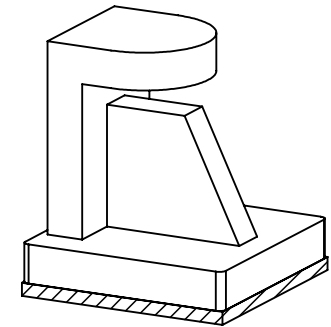
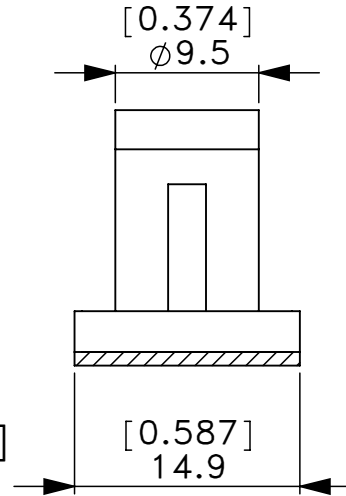
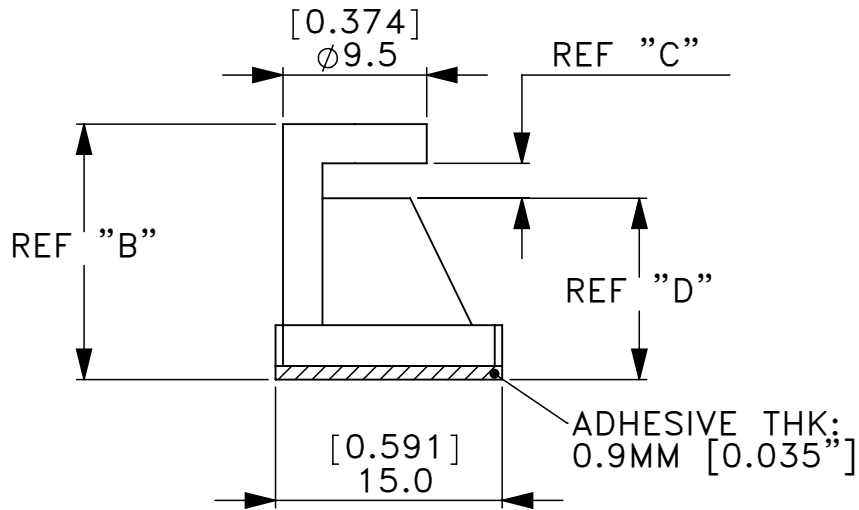

ACTUAL SIZE

DESCRIPTION				NYLON EDGE HOLD PCB SUPPORT WITH ADHESIVE MOUNT		 THIRD ANGLE PROJECTION		Vaisis www.vaisis.com	
DWG DIMENSIONS UNLESS NOTED				DWG. No.	PART No.	DWN	DATE	CHKD	DATE
MM [INCH]				DW-PCBS-UB-6F	SEE TABLE	YW	5/26/2011	YW	5/26/2011
A	INITIAL RELEASE	5/26/2011	GC	TOLERANCES UNLESS NOTED	MATERIAL	COLOR	SCALE	SHEET SIZE	SHEET No.
REV.	DESCRIPTION	DATE	APPROVED	.X=±0.20 [0.008] .XX=±0.10 [0.004] FRAC=±1/64 ANG=1°	NYLON 66	NATURAL	2:1	A	1 OF 1